

NEO-8Q

u-blox 8 GNSS module

Data sheet



Abstract

Technical data sheet describing the NEO-8Q module which provides single GNSS reception (GPS, GLONASS).

Document information

Title	NEO-8Q	
Subtitle	u-blox 8 GNSS module	
Document type	Data sheet	
Document number	UBX-15031913	
Revision and date	R06	16-Dec-2022
Document status	Production Information	

Product status	Corresponding content status	
In Development / Prototype	Objective Specification	Target values. Revised and supplementary data will be published later.
Engineering Sample	Advance Information	Data based on early testing. Revised and supplementary data will be published later.
Initial Production	Early Production Information	Data from product verification. Revised and supplementary data may be published later.
Mass Production / End of Life	Production Information	Document contains the final product specification.

This document applies to the following products:

Product name	Type number	Firmware version	PCN/IN reference
NEO-8Q	NEO-8Q-0-11	ROM SPG 3.01	UBX-20013367, UBX-22039049

u-blox or third parties may hold intellectual property rights in the products, names, logos, and designs included in this document. Copying, reproduction, or modification of this document or any part thereof is only permitted with the express written permission of u-blox. Disclosure to third parties is permitted for clearly public documents only.

The information contained herein is provided "as is" and u-blox assumes no liability for its use. No warranty, either express or implied, is given, including but not limited to, with respect to the accuracy, correctness, reliability, and fitness for a particular purpose of the information. This document may be revised by u-blox at any time without notice. For the most recent documents, visit www.u-blox.com.

Copyright © u-blox AG.

Contents

Document information	2
Contents	3
1 Functional description	5
1.1 Overview	5
1.2 Product features	5
1.3 Performance.....	6
1.4 Block diagram	7
1.5 Supported GNSS constellations	7
1.5.1 GPS	7
1.5.2 GLONASS	7
1.6 Assisted GNSS (A-GNSS).....	7
1.6.1 AssistNow™ Online.....	8
1.6.2 AssistNow™ Offline.....	8
1.6.3 AssistNow™ Autonomous	8
1.7 Augmentation systems	8
1.7.1 Satellite-based augmentation system (SBAS)	8
1.7.2 QZSS	9
1.7.3 Differential GPS (D-GPS).....	9
1.8 Odometer	9
1.9 Broadcast navigation data and satellite signal measurements	9
1.10 Geofencing.....	9
1.11 Message integrity protection	10
1.12 Spoofing detection	10
1.13 EXTINT: External interrupt.....	10
1.13.1 Pin control	10
1.13.2 Aiding	10
1.14 TIMEPULSE	10
1.15 Protocols and interfaces	11
1.16 Interfaces.....	11
1.16.1 UART	11
1.16.2 USB	11
1.16.3 SPI	11
1.16.4 Display data channel (DDC)	11
1.17 Clock generation.....	12
1.17.1 TCXO oscillator.....	12
1.17.2 Real-time clock (RTC)	12
1.18 Power management	12
1.18.1 DC/DC converter	12
1.18.2 Power mode setup.....	12
1.18.3 Continuous mode.....	12

1.18.4 Power save mode	13
1.19 Antenna.....	13
1.19.1 Active antenna control (LNA_EN)	13
1.20 Configuration management	13
1.20.1 Interface selection (D_SEL)	13
2 Pin definition.....	14
2.1 Pin assignment.....	14
3 Electrical specification.....	15
3.1 Absolute maximum rating.....	15
3.2 Operating conditions.....	16
3.3 Indicative current requirements	16
3.4 SPI timing diagrams	17
3.4.1 Timing recommendations.....	17
3.5 DDC timing diagrams	17
4 Mechanical specifications.....	18
5 Reliability tests and approvals.....	19
5.1 Reliability tests.....	19
5.2 Approvals.....	19
6 Product handling and soldering	20
6.1 Packaging	20
6.1.1 Reels	20
6.1.2 Tapes.....	20
6.2 Shipment, storage and handling	21
6.2.1 Moisture sensitivity levels	21
6.2.2 Reflow soldering.....	21
6.2.3 ESD handling precautions	21
7 Default messages	22
8 Labeling and ordering information	23
8.1 Product labeling.....	23
8.2 Explanation of codes	23
8.3 Ordering codes.....	23
Related documents	24
Revision history	24
Contact.....	25

1 Functional description

1.1 Overview

The NEO-8Q standard precision GNSS module is built on the reliable performance of the u-blox 8 GNSS engine, which receives GPS, GLONASS, QZSS and SBAS signals. The NEO-8Q delivers high sensitivity and minimal acquisition times in the industry proven NEO form factor.

The NEO-8Q module features low power consumption and supports advanced power save modes. It also provides message integrity protection, geofencing, spoofing detection, and odometer functionalities.

The NEO-8Q module is an economical choice for best performance and easier RF integration. For RF optimization the NEO-8Q module features an additional front-end LNA for easier antenna integration and a front-end SAW filter for increased jamming immunity. The industry proven NEO form factor allows easy migration from previous NEO generations. Sophisticated RF-architecture and interference suppression ensure maximum performance even in GNSS-hostile environments.

The NEO-8Q module combines a high level of robustness and integration capability with flexible connectivity options. The DDC (I2C compliant) interface provides connectivity and enables synergies with most u-blox cellular modules.

The NEO-8Q module uses a u-blox 8 GNSS chip, qualified according to AEC-Q100 and manufactured in ISO/TS 16949 certified sites. Qualification tests are performed as stipulated in the ISO16750 standard: "Road vehicles – Environmental conditions and testing for electrical and electronic equipment".

The u-blox NEO-8Q module can also benefit from the u-blox AssistNow assistance service. The online service provides GNSS broadcast parameters, for example, ephemeris, almanac data plus time to reduce the receiver's time to first fix significantly and improve acquisition sensitivity. The extended validity of AssistNow Offline data (up to 35 days) and AssistNow Autonomous data (up to 3 days) provide faster acquisition after a long off time.

See section 1.6 for more information concerning the NEO-8Q related AssistNow Assistance.

1.2 Product features

Model	Category	GNSS				Supply	Interfaces				Features				Grade		
	Standard Precision GNSS High Precision GNSS Dead Reckoning Timing	GPS / QZSS GLONASS Galileo BeiDou	Number of Concurrent GNSS	2.7 V – 3.6 V	UART USB SPI DDC (I2C compliant)	Programmable (Flash) Data logging Additional SAW Additional LNA RTC crystal Oscillator Built-in antenna Built-in antenna supply and supervisor Timepulse	Standard Professional Automotive										
NEO-8Q	•	• •	1	•	• • • •	• • • T	1	• • •									

C = Crystal / T = TCXO

1.3 Performance

Parameter	Specification		
Receiver type	72-channel u-blox 8 engine GPS L1C/A, SBAS L1C/A, QZSS L1C/A, QZSS L1-C/A, GLONASS L1OF		
Accuracy of time pulse	RMS	30 ns	
	99%	60 ns	
Frequency of time pulse	0.25 Hz... 10 MHz (configurable)		
Operational limits ¹	Dynamics	≤ 4 g	
	Altitude	50,000 m	
	Velocity	500 m/s	
Velocity accuracy ²	0.05 m/s		
Heading accuracy ²	0.3 degrees		
GNSS		GPS	GLONASS
Horizontal position accuracy ³	Autonomous	2.5 m	4.0 m
	SBAS	2.0 m	
Max navigation update rate ⁴		18 Hz	18 Hz
Time-To-First-Fix ⁵	Cold start	29 s	30 s
	Hot start	1 s	1 s
	Aided starts ⁶	2 s	2 s
Sensitivity ⁷	Tracking & Navigation	-166 dBm	-166 dBm
	Reacquisition	-160 dBm	-156 dBm
	Cold start	-148 dBm	-145 dBm
	Hot start	-157 dBm	-156 dBm

Table 1: NEO-8Q performance in different GNSS modes (default: single reception of GPS incl. QZSS, SBAS)

¹ Assuming Airborne < 4 g platform

² 50% at 30 m/s

³ CEP, 50%, 24 hours static, -130 dBm, > 6 SVs

⁴ Rates with SBAS and QZSS enabled for > 98% fix report rate under typical conditions

⁵ All satellites at -130 dBm

⁶ Dependent on aiding data connection speed and latency

⁷ Demonstrated with a good external LNA

1.4 Block diagram

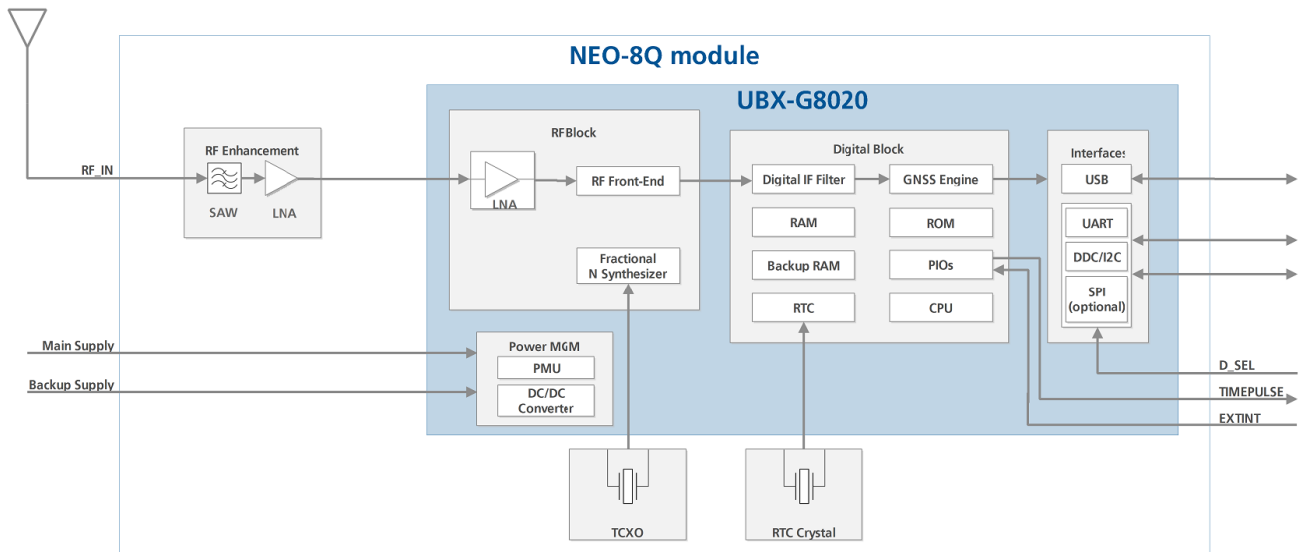

Figure 1: NEO-8Q block diagram

1.5 Supported GNSS constellations

The NEO-8Q module is a single GNSS receiver, which can receive and track either GPS or GLONASS signals. By default the receiver is configured for GPS, including SBAS and QZSS reception.

The augmentation systems SBAS and QZSS can be enabled only if GPS operation is configured.

1.5.1 GPS

The NEO-8Q module is designed to receive and track the L1C/A signals provided at 1575.42 MHz by the global positioning system (GPS). The NEO-8Q module can receive and process GPS concurrently with QZSS and SBAS signals.

1.5.2 GLONASS

The NEO-8Q module can receive and process the GLONASS satellite system as an alternative to the GPS. The u-blox NEO-8Q module is designed to receive and track the L1OF signals GLONASS provides at $1602 \text{ MHz} + k \cdot 562.5 \text{ kHz}$, where k is the satellite's frequency channel number ($k = -7, \dots, 5, 6$). The ability to process GLONASS L1OF satellite signals allows design of GLONASS receivers where required by regulations.

To take advantage of GPS and GLONASS, dedicated hardware preparation must be made during the design-in phase. See the NEO-8Q / NEO-M8 Hardware Integration Manual [1] for u-blox design recommendations.

1.6 Assisted GNSS (A-GNSS)

Supply of GNSS receiver assistance information, such as ephemeris, almanac, rough user position and time, will reduce the time to first fix significantly and improve acquisition sensitivity. All u-blox G8020-based products support the u-blox AssistNow Online and AssistNow Offline A-GNSS services, support AssistNow Autonomous, and are OMA SUPL-compliant.

1.6.1 AssistNow™ Online

With AssistNow Online, an internet-connected host downloads assistance data from the u-blox AssistNow Online service to the receiver at system start-up. The Multi-GNSS Assistance (MGA) service is an HTTP protocol-based network operator-independent service.

Supplying assistance information, such as ephemeris, almanac, a rough last position, and time, can reduce the time to first fix significantly and improve acquisition sensitivity.

 The AssistNow Online service provides data for GPS, GLONASS and QZSS.

1.6.2 AssistNow™ Offline

With AssistNow Offline service, users can download long-term orbit data over the internet at their convenience. The orbit data can be stored in the memory of the application processor for subsequent download to the NEO-8Q module. Thus, the function enables a position fix within seconds, even when no network is available. AssistNow Offline offers augmentation for up to 35 days.

 The AssistNow Offline service provides data for GPS and GLONASS.

1.6.3 AssistNow™ Autonomous

AssistNow Autonomous operation provides aiding information without the need for a host or external network connection. Based on previous broadcast satellite ephemeris data downloaded to and stored by the GNSS receiver, AssistNow Autonomous automatically generates accurate predictions of satellite orbital data (“AssistNow Autonomous data”) that is usable for future GNSS position fixes. The concept capitalizes on the periodic nature of GNSS satellite orbits by capturing strategic ephemeris data at specific times of the day. For NEO-8Q modules, AssistNow Autonomous can calculate GPS-only orbit predictions for up to 3 days.

u-blox AssistNow Autonomous benefits are:

- Faster fix in situations where GNSS satellite signals are weak
- No connectivity required
- Compatible with AssistNow Online (can work stand-alone, or in tandem with AssistNow Online service)
- No integration effort; calculations are done in the background, transparent to the user.

 For more details on A-GNSS see the u-blox 8 / u-blox M8 Receiver Description Including Protocol Specification [2].

1.7 Augmentation systems

1.7.1 Satellite-based augmentation system (SBAS)

The u-blox NEO-8Q module supports reception of SBAS broadcast signals. These systems supplement GNSS data with additional regional or wide area GPS augmentation data. The system broadcasts range correction and integrity information via satellite which can be used by GNSS receivers to improve resulting precision. SBAS satellites can also be used as additional signals for ranging (navigation), further enhancing availability. The following SBAS types are supported: EGNOS, MSAS, and WAAS.

 For more details see the u-blox 8 / u-blox M8 Receiver Description Including Protocol Specification [2].

1.7.2 QZSS

The Quasi-Zenith Satellite System (QZSS) is a regional navigation satellite system that transmits additional GPS L1C/A signals for the Pacific region covering Japan and Australia. The NEO-8Q module is able to receive and track these signals concurrently with GPS signals, resulting in better availability especially under challenging signal conditions, for example, in urban canyons.

 The L1-SAIF signal provided by QZSS is not supported.

1.7.3 Differential GPS (D-GPS)

u-blox receivers support differential-GPS (D-GPS) data according to RTCM specification 10402.3 [4]: The use of D-GPS improves GPS position accuracy. The RTCM implementation supports the following RTCM 2.3 messages.

Message type	Description
1	Differential GPS corrections
2	Delta differential GPS corrections
3	GPS reference station parameters
9	GPS partial correction set

Table 2: Supported RTCM 2.3 messages

 RTCM corrections cannot be used together with SBAS.

 For more details see the u-blox 8 / u-blox M8 Receiver Description Including Protocol Specification [2].

1.8 Odometer

The odometer function provides information on the traveled ground distance (in meters) based on the position and Doppler-based velocity output from the navigation solution. For each computed distance since the last odometer reset, the odometer estimates a 1-sigma accuracy value. The total cumulative ground distance is maintained and saved in the BBR memory.

 The odometer feature is disabled by default. For more details see the u-blox 8 / u-blox M8 Receiver Description Including Protocol Specification [2].

1.9 Broadcast navigation data and satellite signal measurements

u-blox 8 receivers can output all the GNSS broadcast data upon reception from tracked satellites. This includes all the supported GNSS signals plus the augmentation services SBAS and QZSS. The receiver also makes available the tracked satellite signal information, that is, raw code phase and Doppler measurements in a form aligned to the ETSI mobile cellular location services protocol (RRLP) [6]. For more details see the u-blox 8 / u-blox M8 Receiver Description Including Protocol Specification [2].

1.10 Geofencing

The u-blox NEO-8Q module supports up to four circular Geofencing areas defined on the Earth's surface using a 2D model. Geofencing is active when at least one Geofence is defined, the current status can be found by polling the receiver. A PIO pin can be nominated to indicate status to, for example, wake up a host on activation.

1.11 Message integrity protection

The NEO-8Q module provides a function to prevent a third-party interfering with the UBX message stream sent from receiver to host. The security mechanism essentially “signs” nominated messages with a following message containing an md5 generated hash of the nominated message. This message signature is then compared with the one generated by the host to determine if the message data has been altered. The hash algorithm seed can use one fixed secret ID-key set by eFuse in production or a dynamic ID-key set by host enabling users to detect “Man-in-the-middle” style attacks.

1.12 Spoofing detection

Spoofing is a process whereby a malicious third party tries to control the reported position via a “fake” GNSS broadcast signal. This may result in the form of reporting incorrect position, velocity, or time. To combat against this the NEO-8Q module includes anti-spoofing measures to alert the host when signals appear to be suspicious. The receiver combines a number of checks on the received signals looking for inconsistencies across several parameters.

 This feature does not guarantee detection of all spoofing attacks.

1.13 EXTINT: External interrupt

EXTINT is an external interrupt pin with fixed input voltage thresholds with respect to VCC. It can be used for control of the receiver or for aiding.

For more information about how to implement and configure these features, see the u-blox 8 / u-blox M8 Receiver Description including Protocol Specification [2] and the NEO-8Q / NEO-M8 Hardware integration manual [1].

1.13.1 Pin control

The pin control feature allows overriding the automatic active/inactive cycle of power save mode. The state of the receiver can be controlled through the **EXTINT** pin.

The receiver can also be forced OFF using **EXTINT** when power save mode is not active.

1.13.2 Aiding

The **EXTINT** pin can be used to supply time or frequency aiding data to the receiver.

For time aiding, hardware time synchronization can be achieved by connecting an accurate time pulse to the **EXTINT** pin.

Frequency aiding can be implemented by connecting a periodic rectangular signal with a frequency up to 500 kHz and an arbitrary duty cycle (low/high phase duration must not be shorter than 50 ns) to the **EXTINT** pin. Provide the applied frequency value to the receiver using UBX messages.

1.14 TIMEPULSE

A configurable time pulse signal is available with all u-blox NEO modules. The TIMEPULSE output generates pulse trains synchronized with GPS or UTC time grid with intervals configurable over a wide frequency range. Thus it may be used as a low frequency time synchronization pulse or as a high frequency reference signal.

By default the time pulse signal is configured to 1 pulse per second. For more information see the u-blox 8 / u-blox M8 Receiver Description including Protocol Specification [2].

1.15 Protocols and interfaces

Protocol	Type
NMEA 0183, version 4.0 (V2.1 V2.3 or V4.1 configurable)	Input/output, ASCII
UBX	Input/output, binary, u-blox proprietary
RTCM	Input message, 1, 2, 3, 9

Table 3: Available protocols

All protocols are available on UART, USB, DDC (I2C compliant) and SPI. For specification of the various protocols see the u-blox 8 / u-blox M8 Receiver Description including Protocol Specification [2].

1.16 Interfaces

A number of interfaces are provided either for data communication or memory access. The embedded firmware uses these interfaces according to their respective protocol specifications.

1.16.1 UART

The NEO-8Q module includes one UART interface, which can be used for communication to a host. It supports configurable baud rates. For supported baud rates see the u-blox 8 / u-blox M8 Receiver Description including Protocol Specification [2].

 Designs must allow access to the UART and the **SAFEBOOT_N** function pin for future service and reconfiguration.

1.16.2 USB

A USB interface, which is compatible to USB version 2.0 FS (Full Speed, 12 Mbit/s), can be used for communication as an alternative to the UART. The pull-up resistor on pin USB_DP is integrated to signal a full-speed device to the host. The VDD_USB pin supplies the USB interface. The u-blox USB (CDC-ACM) driver supports Windows Vista and Windows 7 and 8 operating systems. A separate driver (CDC-ACM) is not required for Windows 10 which has a built-in USB-serial driver. However, plugging initially into an internet-connected Windows 10 PC will download the u-blox combined sensor and VCP driver package.

USB drivers can be downloaded from the u-blox web site, www.u-blox.com.

1.16.3 SPI

The SPI interface is designed to allow communication to a host CPU. The interface can be operated in slave mode only. The maximum transfer rate using SPI is 125 kB/s and the maximum SPI clock frequency is 5.5 MHz, see Figure 3. Note that SPI is not available in the default configuration because its pins are shared with the UART and DDC interfaces. The SPI interface can be enabled by connecting D_SEL (Pin 2) to ground (see section 1.20.1).

1.16.4 Display data channel (DDC)

An I2C compliant DDC interface is available for communication with an external host CPU or u-blox cellular modules. The interface can be operated in slave mode only. The DDC protocol and electrical interface are fully compatible with Fast Mode of the I2C industry standard. Since the maximum SCL clock frequency is 400 kHz, the maximum transfer rate is 400 kb/s.

1.17 Clock generation

1.17.1 TCXO oscillator

NEO-8Q module uses a TCXO reference oscillator. The TCXO allows accelerated weak signal acquisition, enabling faster start and reacquisition times.

Oscillators used on the NEO-8Q module are carefully selected and screened for stability and against frequency perturbations across the full operating range (−40 °C to +85 °C). Careful selection and qualification of critical parts, such as GNSS oscillators, has resulted in u-blox modules being the most reliable positioning modules in the industry, particularly in challenging conditions.

1.17.2 Real-time clock (RTC)

The RTC is driven by a 32768 Hz oscillator using an RTC crystal. If the main supply voltage fails, and a battery is connected to V_BCKP, parts of the receiver switch off, but the RTC still runs providing a timing reference for the receiver. This operating mode is called hardware backup mode, which enables all relevant data to be saved in the backup RAM to allow a hot or warm start later.

1.18 Power management

u-blox 8 technology offers a power-optimized architecture with built-in autonomous power saving functions to minimize power consumption at any given time. Furthermore, the receiver can be used in two operating modes: continuous mode for best performance or power save mode for optimized power consumption, respectively.

1.18.1 DC/DC converter

The NEO-8Q module integrates a DC/DC converter, allowing reduced power consumption especially when using a main supply voltage above 2.5 V.



For more information see the NEO-8Q / NEO-M8 Hardware Integration Manual [1].

1.18.2 Power mode setup

The u-blox NEO-8Q module can be configured to run in either continuous mode or a choice of power save mode configurations. A template of power mode settings can be used to easily select typical power mode setups to cover the majority of users' requirements.

For specific power saving applications, the user has the option to fully configure via the power save mode configuration. For more information see section 1.18.4.

The u-blox 8 receivers' power mode setup offers a choice of continuous operation and preset power save mode configurations:

- Continuous (default) mode for best GNSS performance vs. power consumption
- Continuous with no compromise in power consumption
- A 1 Hz cyclic tracking mode for aggressive power reduction
- Choice of 2 or 4 Hz cyclic tracking modes for typical wearable applications
- ON/OFF interval mode

1.18.3 Continuous mode

Continuous mode uses the acquisition engine at full performance resulting in the shortest possible TTFF and the highest sensitivity. It searches for all possible satellites until the Almanac is completely downloaded. The receiver then switches to the tracking engine to lower power consumption.

Thus, a lower tracking current consumption level will be achieved when:

- A valid GNSS position is obtained
- The entire Almanac has been downloaded
- The Ephemeris for each satellite in view is valid

1.18.4 Power save mode

For power sensitive applications, u-blox 8 receivers provide a power save mode for reduced power consumption.

The power save mode provides two dedicated methods, ON/OFF and cyclic tracking, that reduce the average current consumption in different ways to match the needs of the specific application. These operations can be set by using a specific UBX message.

 For more information about power management strategies, see the u-blox 8 / u-blox M8 Receiver Description including Protocol Specification [2].

1.19 Antenna

The NEO-8Q module is designed for use with passive⁸ and active⁹ antennas.

Parameter	Specification	
Antenna type	Passive and active antenna	
Active antenna recommendations	Minimum gain	15 dB (to compensate signal loss in RF cable)
	Maximum gain	30 dB
	Maximum noise figure	1.5 dB

Table 4: Antenna specifications for NEO-8Q module

1.19.1 Active antenna control (LNA_EN)

The LNA_EN pin can be used to turn on and off an external LNA or an active antenna. This reduces power consumption in power save mode (backup mode). This pin is available on the NEO-8Q module.

1.20 Configuration management

Configuration settings can be modified with UBX configuration messages. The modified settings remain effective until power-down or reset. If these settings have been stored in battery-backup RAM, then the modified configuration will be retained as long as the backup battery supply is not interrupted.

1.20.1 Interface selection (D_SEL)

At startup Pin 2 (D_SEL) determines which data interfaces are used for communication. If D_SEL is set high or left open, UART and DDC become available. If D_SEL is set low, that is, connected to ground, the NEO-8Q module can communicate to a host via SPI.

Pin #	D_SEL="1" (left open)	D_SEL="0" (connected to GND)
20	UART TX	SPI MISO
21	UART RX	SPI MOSI
19	DDC SCL	SPI CLK
18	DDC SDA	SPI CS_N

Table 5: Data interface selection by D_SEL

⁸ For integrating NEO-8Q module with Cellular products, see the NEO-8Q / NEO-M8 Hardware integration manual [1].

⁹ For information on using active antennas with NEO-8Q module, see the NEO-8Q / NEO-M8 Hardware integration manual [1].

2 Pin definition

2.1 Pin assignment

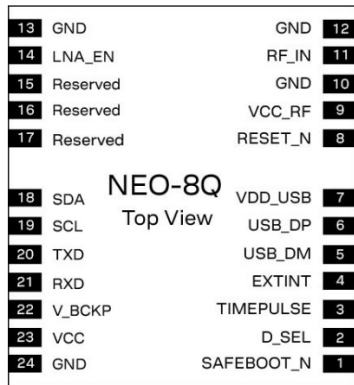

PIO = Peripheral input output

Figure 2: Pin assignment



No.	Name	PIO no.	I/O	Description
1	SAFEBOOT_N	-	I	For future service and reconfiguration, leave OPEN
2	D_SEL	-	I	Interface select
3	TIMEPULSE	11	O	Time pulse (1PPS)
4	EXTINT	13	I	External interrupt pin
5	USB_DM	-	I/O	USB data
6	USB_DP	-	I/O	USB data
7	VDD_USB	-	I	USB supply
8	RESET_N	-	I	RESET_N
9	VCC_RF	-	O	Output voltage RF section
10	GND	-	I	Ground
11	RF_IN	-	I	GNSS signal input
12	GND	-	I	Ground
13	GND	-	I	Ground
14	LNA_EN	16	O	Antenna / External LNA control
15	Reserved	-	-	Reserved
16	Reserved	-	-	Reserved
17	Reserved	-	-	Reserved
18	SDA / SPI CS_N	9	I/O	DDC data if D_SEL = 1 (or open) SPI chip select if D_SEL = 0
19	SCL / SPI CLK	8	I/O	DDC clock if D_SEL = 1 (or open) SPI clock if D_SEL = 0
20	TXD / SPI MISO	6	O	Serial port if D_SEL = 1 (or open) SPI MISO if D_SEL = 0
21	RXD / SPI MOSI	7	I	Serial port if D_SEL = 1 (or open) SPI MOSI if D_SEL = 0
22	V_BCKP	-	I	Backup voltage supply
23	VCC	-	I	Supply voltage
24	GND	-	I	Ground

Table 6: Pinout



Pins designated as Reserved should not be used. For more information about pinouts, see the NEO-8Q / NEO-M8 Hardware integration manual [1].

3 Electrical specification

-  The limiting values given are in accordance with the Absolute Maximum Rating System (IEC 134). Stress above one or more of the limiting values may cause permanent damage to the device. These are stress ratings only and operation of the device at these or at any other conditions above those given in the characteristics sections of the specification is not implied. Exposure to these limits for extended periods may affect device reliability.
-  Where application information is given, it is advisory only and does not form part of the specification. For more information see the NEO-8Q / NEO-M8 Hardware integration manual [1].

3.1 Absolute maximum rating

Parameter	Symbol	Condition	Min	Max	Units
Power supply voltage	VCC		-0.5	3.6	V
Backup battery voltage	V_BCKP		-0.5	3.6	V
USB supply voltage	VDD_USB		-0.5	3.6	V
Input pin voltage	Vin	If VCC < 3.1V	-0.5	VCC+0.5	V
		If VCC >= 3.1V	-0.5	3.6	V
	Vin_usb		-0.5	VDD_USB	V
DC current through any digital I/O pin (except supplies)	Ipin			10	mA
VCC_RF output current	ICC_RF			100	mA
Input power at RF_IN	Prfin	source impedance = 50 Ω, continuous wave		15	dBm
Storage temperature	Tstg		-40	85	°C

Table 7: Absolute maximum ratings

-  Stressing the device beyond the “Absolute Maximum Ratings” may cause permanent damage. These are stress ratings only. The product is not protected against overvoltage or reversed voltages. If necessary, voltage spikes exceeding the power supply voltage specification, given in table above, must be limited to values within the specified boundaries by using appropriate protection diodes.

3.2 Operating conditions

All specifications are at an ambient temperature of 25 °C. Extreme operating temperatures can significantly impact specification values. Applications operating near the temperature limits should be tested to ensure the specification.

Parameter	Symbol	Min	Typical	Max	Units	Condition
Power supply voltage	VCC	1.65		3.6	V	
Supply voltage USB	VDDUSB	3.0	3.3	3.6	V	
Backup battery voltage	V_BCKP	1.4		3.6	V	
Backup battery current	I_BCKP		15		µA	V_BCKP = 1.8 V, VCC = 0 V
SW backup current	I_SWBCKP		22		µA	VCC = 3 V
			30		µA	VCC = 3 V
Input pin voltage range	V _{in}	0		VCC	V	
Digital IO pin low level input voltage	V _{il}	0		0.2*VCC	V	
Digital IO pin high level input voltage	V _{ih}	0.7*VCC		VCC	V	
Digital IO pin low level output voltage	V _{ol}			0.4	V	I _{ol} = 4mA
Digital IO pin high level output voltage	V _{oh}	VCC-0.4			V	I _{oh} = 4mA
Pull-up resistor for RESET_N (internal)	R _{pu}		11		kΩ	
USB_DM, USB_DP	V _{inU}	Compatible with USB with 27 Ω series resistance				
VCC_RF voltage	VCC_RF		VCC-0.1		V	
VCC_RF output current	ICC_RF			50	mA	
Receiver chain noise figure	NF _{tot}		2.0		dB	
Operating temperature	T _{opr}	-40		85	°C	

Table 8: Operating conditions

Operation beyond the specified operating conditions can affect device reliability.

3.3 Indicative current requirements

Table 9 lists examples of the total system supply current for a possible application.

Values in Table 9 are provided for customer information only as an example of typical power requirements. The values are characterized on samples, actual power requirements can vary depending on FW version used, external circuitry, number of SVs tracked, signal strength, type of start as well as time, duration and conditions of test.

Parameter	Symbol	Typ. GPS / QZSS / SBAS	Typ. GLONASS	Max	Units	Condition
Max supply current ¹⁰	I _{ccp}			67	mA	Estimated at 3 V
	I _{cc acquisition} ¹¹	23	23		mA	Estimated at 3 V
Average supply current ^{12, 13}	I _{cc tracking} (continuous)	22	21		mA	Estimated at 3 V
	I _{cc tracking} (Power save mode / 1 Hz)	10.2	10.2		mA	Estimated at 3 V

Table 9: Indicative power requirements at 3.0 V

¹⁰ Use this figure to dimension maximum current capability of power supply. Measurement of this parameter with 1 Hz bandwidth.

¹¹ Average current from start-up until the first fix.

¹² Use this figure to determine required battery capacity.

¹³ Simulated GNSS constellation using power levels of -130 dBm. VCC = 3.0 V

- For more information about power requirements, see the NEO-8Q / NEO-M8 Hardware integration manual [1].
- For more information on how to noticeably reduce current consumption, see the Power Management Application Note [5].

3.4 SPI timing diagrams

To avoid incorrect operation of the SPI, the user needs to comply with certain timing conditions. Consider the following signals for timing constraints:

Symbol	Description
SPI CS_N (SS_N)	Slave select signal
SPI CLK (SCK)	Slave clock signal

Table 10: Symbol description

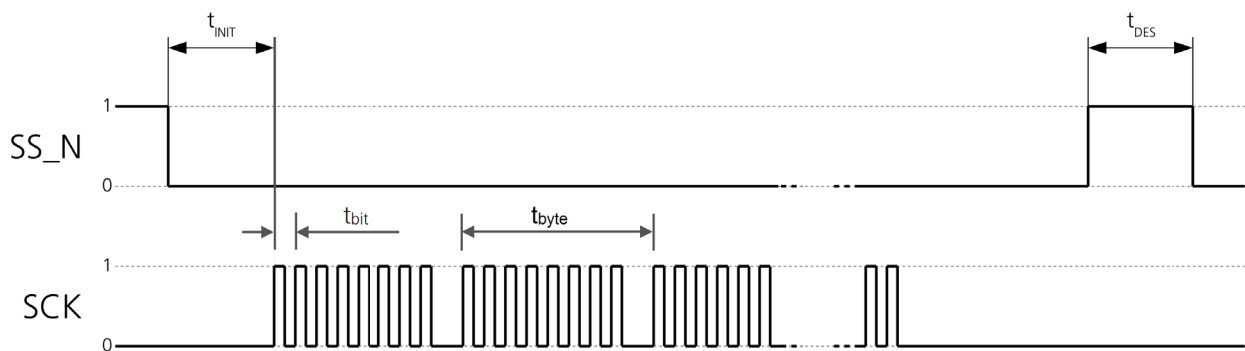

Figure 3: SPI timing diagram

3.4.1 Timing recommendations

The SPI timing recommendations are given below.

Parameter	Description	Recommendation
t_{INIT}	Minimum initialization time	10 μ s
t_{DES}	Deselect time	1 ms
t_{bit}	Minimum bit time	180 ns (5.5 MHz max bit frequency)
t_{byte}	Minimum byte period	8 μ s (125 kHz max byte frequency)

Table 11: SPI timing recommendations

- The values in the above table result from the requirement of an error-free transmission. By allowing just a few errors and disabling the glitch filter, the bit rate can be increased considerably.

3.5 DDC timing diagrams

The DDC interface is I2C fast mode compliant. For timing parameters consult the I2C standard.

- The maximum bit rate is 400 kb/s. The interface stretches the clock when slowed down when serving interrupts, so real bit rates may be slightly lower.

4 Mechanical specifications

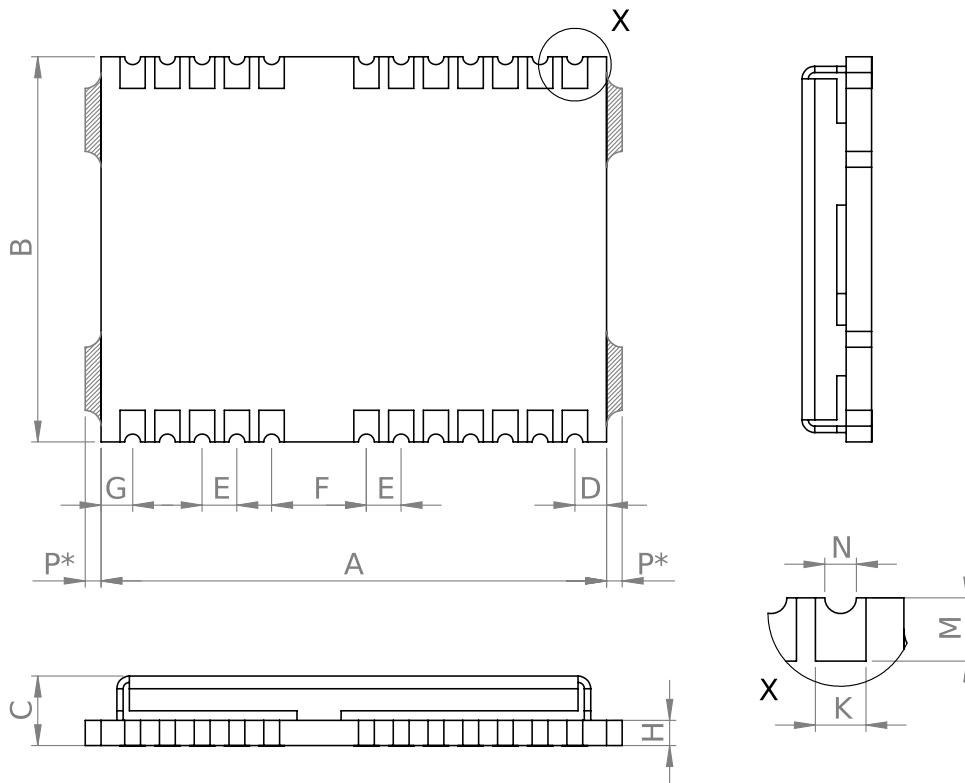

Figure 4 NEO-8Q mechanical drawing

Symbol	Min [mm]	Typ. [mm]	Max [mm]	
A	15.9	16.0	16.1	
B	12.1	12.2	12.3	
C	2.2	2.4	2.6	
D	0.9	1.0	1.1	
E	1.0	1.1	1.2	
F	2.9	3.0	3.1	
G	0.9	1.0	1.1	
H	-	0.82	-	
K	0.7	0.8	0.9	
M	0.8	0.9	1.0	
N	0.4	0.5	0.6	
P*	0.0	-	0.5	The de-paneling residual tabs may be on either side (not both)
Weight		1.6 g		

Table 12 NEO-8Q mechanical dimensions

- The mechanical picture of the de-paneling residual tabs (P*) is an approximate representation. The shape and position of the residual tab may vary.
- When designing the component keep-out area, note that the de-paneling residual tabs can be on either side of the module (not both).
- For information about the paste mask and footprint, see the NEO-8Q / NEO-M8 Hardware integration manual [1].

5 Reliability tests and approvals

5.1 Reliability tests

 All NEO-8Q modules are based on AEC-Q100 qualified GNSS chips.

Tests for product family qualifications are according to ISO 16750 "Road vehicles – environmental conditions and testing for electrical and electronic equipment", and appropriate standards.

5.2 Approvals

The NEO-8Q module complies with the Directives 2011/65/EU and 2015/863/EU of the European Parliament and the Council on the Restriction of Use of certain Hazardous Substances (RoHS).

6 Product handling and soldering

6.1 Packaging

To enable efficient production, production lot set-up and tear-down, the NEO-8Q modules are delivered as hermetically sealed, reeled tapes. For more information see the u-blox Package Information Guide [3].

6.1.1 Reels

Each reel has 250 NEO-8Q modules. The NEO-8Q modules are shipped on Reel Type B, as specified in the u-blox Package Information Guide [3].

6.1.2 Tapes

The dimensions and orientations of the tapes for NEO-8Q modules are specified in Figure 5.

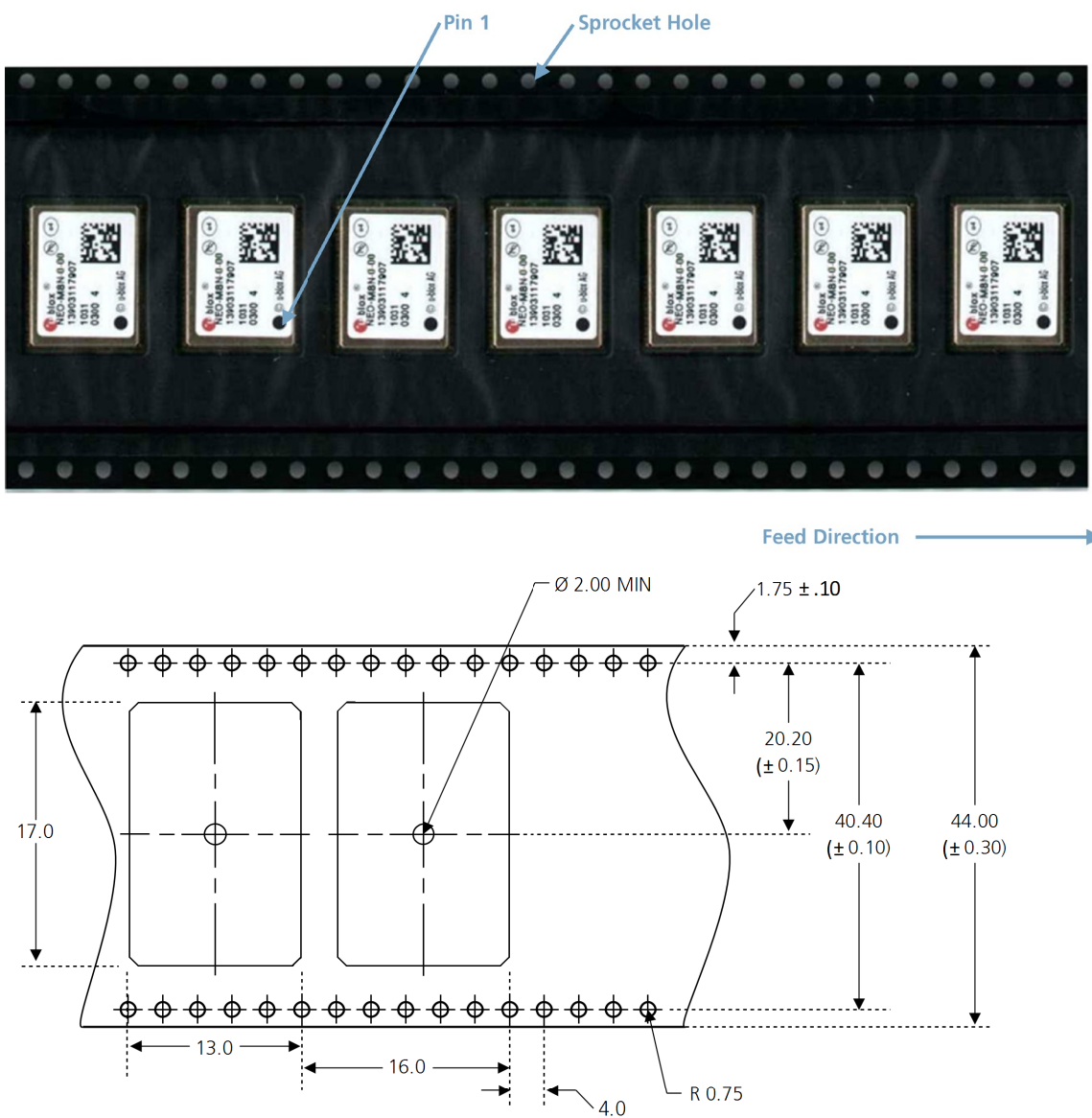



Figure 5: Dimensions and orientation for NEO-8Q modules on tape

6.2 Shipment, storage and handling

For important information regarding shipment, storage and handling see the u-blox Package Information Guide [3].

6.2.1 Moisture sensitivity levels

The moisture sensitivity level (MSL) relates to the packaging and handling precautions required. The NEO-8Q modules are rated at MSL level 4.

 For MSL standard see IPC/JEDEC J-STD-020, which can be downloaded from www.jedec.org.

 For more information regarding MSL see the u-blox Package Information Guide [3].

6.2.2 Reflow soldering

Reflow profiles are to be selected according to u-blox recommendations (see the NEO-8Q / NEO-M8 Hardware integration manual [1]).

6.2.3 ESD handling precautions

 NEO-8Q modules are electrostatic sensitive devices (ESD). Observe precautions for handling! Failure to observe these precautions can result in severe damage to the GNSS receiver!

GNSS receivers are electrostatic sensitive devices (ESD) and require special precautions when handling. Due to the risk of electrostatic charges, exercise particular care when handling patch antennas. In addition to standard ESD safety practices, take the following measures into account whenever handling the receiver:

- Unless there is a galvanic coupling between the local GND (i.e. the work table) and the PCB GND, the first point of contact when handling the PCB must always be between the local GND and PCB GND.
- Before mounting an antenna patch, connect ground of the device.
- When handling the RF pin, do not come into contact with any charged capacitors and be careful when contacting materials that can develop charges (e.g. patch antenna ~10 pF, coax cable ~50-80 pF/m, soldering iron).
- To prevent electrostatic discharge through the RF input, do not touch any exposed antenna area. If there is any risk that such exposed antenna area is touched in a non-ESD protected work area, implement proper ESD protection measures in the design.
- When soldering RF connectors and patch antennas to the receiver's RF pin, make sure to use an ESD-safe soldering iron (tip).

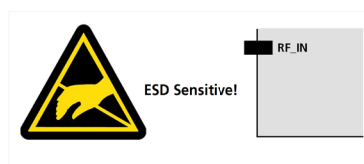

7 Default messages

Interface	Settings
UART Output	9600 baud, 8 bits, no parity bit, 1 stop bit. Configured to transmit both NMEA and UBX protocols, but only the following NMEA (and no UBX) messages have been activated at start-up: GGA, GLL, GSA, GSV, RMC, VTG, TXT
USB Output	Configured to transmit both NMEA and UBX protocols, but only the following NMEA (and no UBX) messages have been activated at start-up: GGA, GLL, GSA, GSV, RMC, VTG, TXT USB power mode: Bus-powered
UART Input	9600 baud, 8 bits, no parity bit, 1 stop bit, Autobauding disabled. Automatically accepts following protocols without need of explicit configuration: UBX, NMEA, RTCM The GNSS receiver supports interleaved UBX and NMEA messages.
USB Input	Automatically accepts following protocols without need of explicit configuration: UBX, NMEA The GPS receiver supports interleaved UBX and NMEA messages. USB power mode: Bus-powered
DDC	Fully compatible with the I2C industry standard, available for communication with an external host CPU or u-blox cellular modules, operated in slave mode only. Default messages activated. NMEA and UBX are enabled as input messages, only NMEA as output messages. Maximum bit rate 400 kb/s.
SPI	Allow communication to a host CPU, operated in slave mode only. Default messages activated. SPI is not available in the default configuration.
TIMEPULSE (1 Hz Nav)	1 pulse per second, synchronized at rising edge, pulse length 100 ms

Table 13: Default messages

 Refer to the u-blox 8 / u-blox M8 Receiver Description Including Protocol Specification [2] for information about further settings.

8 Labeling and ordering information

8.1 Product labeling

The labeling of u-blox NEO GNSS modules includes important product information. The location of the NEO-8Q product type number is shown in Figure 6.

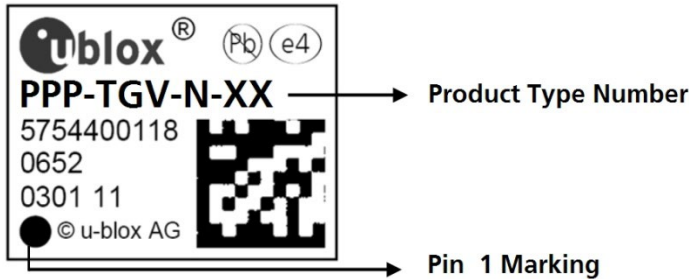

Figure 6: Location of product type number on u-blox NEO-8Q module label

8.2 Explanation of codes

Three different product code formats are used. The **Product name** is used in documentation such as this data sheet and identifies all u-blox M8 products, independent of packaging and quality grade. The **Ordering code** includes options and quality, while the **Type number** includes the hardware and firmware versions. Table 14 shows the structure of these three different formats.

Format	Structure
Product name	PPP-TGV
Ordering code	PPP-TGV-N
Type number	PPP-TGV-N-XX

Table 14: Product code formats

The parts of the product code are explained in Table 15.

Code	Meaning	Example
PPP	Product family	NEO
TG	Platform	8 = u-blox 8
V	Variant	Function set (A-Z), T = Timing, R = DR, etc.
N	Option / Quality grade	Describes standardized functional element or quality grade. 0 = Default variant, A = Automotive
XX	Product detail	Describes product details or options such as hard- and software revision, cable length, etc.

Table 15: Part identification code

8.3 Ordering codes

Ordering code	Product
NEO-8Q-0	u-blox 8 GNSS LCC Module, TCXO, SAW, LNA, 12.2 x 16 mm, 250 pcs/reel

Table 16: Product ordering codes for professional grade module

Product changes affecting form, fit or function are documented by u-blox. For a list of Product Change Notifications (PCNs) see our website.

Related documents

- [1] NEO-8Q / NEO-M8 Hardware integration manual, doc. no. [UBX-15029985](#)
- [2] u-blox 8 / u-blox M8 Receiver Description including Protocol Specification v15.00-18.00 (Public version), doc. no. [UBX 13003221](#)
- [3] u-blox Package Information Guide, doc. no. [UBX-14001652](#)
- [4] RTCM 10402.3 Recommended Standards for Differential GNSS, Ver. 2.3, RTCM AUG. 20, 2001
- [5] Power Management Application Note, doc. no. [UBX-13005162](#)
- [6] Radio Resource LCS Protocol (RRLP), (3GPP TS 44.031 version 11.0.0 Release 11)

 For regular updates to u-blox documentation and to receive product change notifications, register on our homepage (www.u-blox.com).

Revision history

Revision	Date	Name	Comments
R01	25-Apr-2016	byou	Objective Specification.
R02	25-May-2016	julu	Advance Information.
R03	26-Jul-2016	byou	Production Information
R04	24-May-2019	jesk	Updated sections 1.6.3 (AssistNow Autonomous), 3.1 (Absolute maximum rating) and 5.2 (RoHS statement), added PIO numbers in 2.1
R05	30-Apr-2020	msul	Updated type number and PCN reference in page 2
R06	16-Dec-2022	skar	Chapter Mechanical specifications updated with information on de-paneling residual tabs

Contact

u-blox AG

Address: Zürcherstrasse 68
8800 Thalwil
Switzerland

For further support and contact information, visit us at www.u-blox.com/support.